

FEMAŞ VİBRASYON MOTORU

TEKNİK BİLGİLERİ

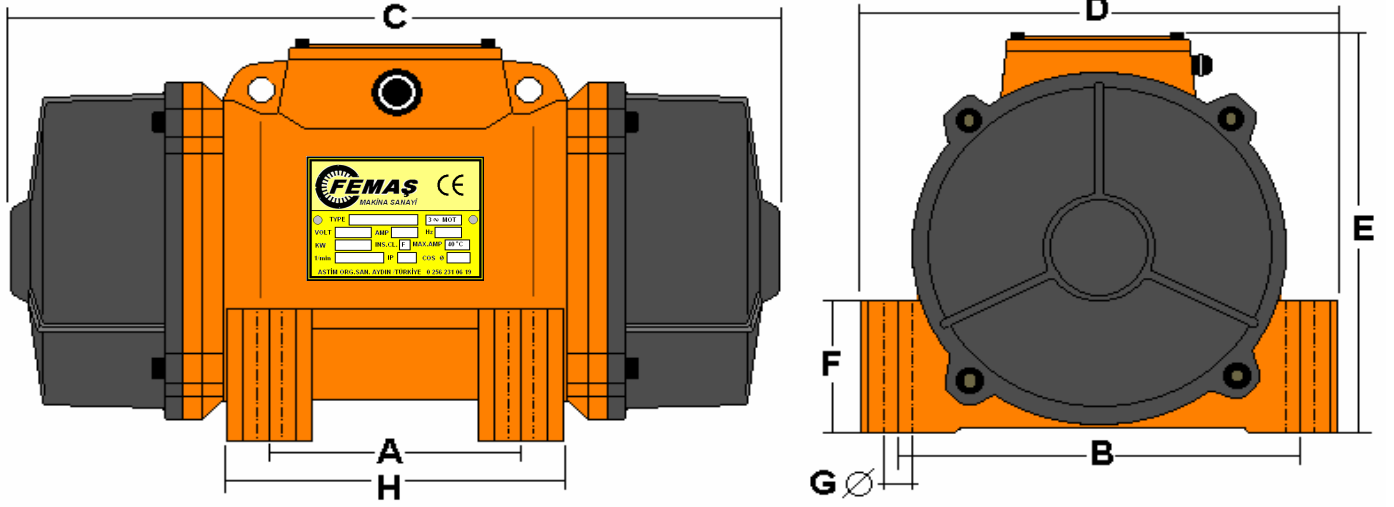

CINSİ	KGF	KW	DEV.DAK.	A	B	C	D	E	F	G	H	AGIRLIK
FV2-A1	390	0,18	3000 D/D	90	125	215	150	150	43	8	112	8
FV2-A2	520	0,25	3000 D/D	90	125	215	150	150	43	8	112	8,5
FV2-B1	860	0,37	3000 D/D	90	150	300	175	165	50	11	120	12
FV2-B2	1100	0,55	3000 D/D	90	150	300	175	165	50	11	120	13
FV2-C1	1700	0,75	3000 D/D	103	180	315	220	205	65	12	145	20
FV2-C2	2200	1,1	3000 D/D	103	180	315	220	205	65	12	145	21
FV2-D1	2900	1,5	3000 D/D	103	180	315	220	205	68	12	145	30
FV2-D2	3800	2,2	3000 D/D	103	180	315	220	205	68	12	145	33
FV2-D3	4450	3	3000 D/D	103	180	315	220	205	68	12	145	35
FV2-E1	6370	4	3000 D/D	130	240	410	290	245	85	17	180	

FV4-A1	180	0,18	1500 D/D	90	125	215	150	150	43	8	112	9
FV4-B1	285	0,25	1500 D/D	90	150	300	175	165	43	8	112	12
FV4-B2	430	0,37	1500 D/D	90	150	300	175	165	50	11	120	14
FV4-C1	800	0,55	1500 D/D	120	180	315	210	205	69	11	156	20
FV4-D1	970	0,75	1500 D/D	140	190	315	230	210	71	12	178	35
FV4-D2	1380	1,1	1500 D/D	140	190	315	230	210	71	12	178	38
FV4-E1	2120	1,5	1500 D/D	130	240	410	290	245	85	17	180	55
FV4-E2	3180	2,2	1500 D/D	130	240	425	290	245	85	17	180	58
FV4-E3	4240	3	1500 D/D	130	240	425	290	245	85	17	180	65
FV4-E4	5300	4	1500 D/D	130	240	490	290	245	85	17	180	

FV6-C1	300	0,37	1000 D/D	120	180	315	210	205	69	12	156	20
FV6-D1	570	0,55	1000 D/D	140	190	345	230	210	71	12	178	32
FV6-D2	915	0,75	1000 D/D	140	190	385	230	210	71	12	178	38
FV6-E1	1500	1,1	1000 D/D	130	240	440	290	245	85	17	180	60
FV6-E2	1980	1,5	1000 D/D	130	240	490	290	245	85	17	180	66
FV6-E3	2420	2,2	1000 D/D	130	240	490	290	245	85	17	180	76

Ölçüler mm. Birimindedir.